

Barriera mobile insonorizzante – IBMM/IBMB

Quando

Le barriere mobili modello IBMM (monoassorbente) e IBMB (biassorbente), ad elevato potere fonoassorbente e fonoisolante, vengono impiegate in diversi processi industriali quali efficaci mezzi di confinamento acustico qualora non sia possibile o vantaggioso realizzare cabine o pareti fisse.

Descrizione

Le barriere mobili modello IBM sono dotate di ruote per una facile movimentazione e, attraverso appositi ganci rapidi, possono essere unite tra di loro per formare pareti di forma lineare o ad angolo o per delimitare spazi chiusi su tre o quattro lati a seconda delle esigenze.

Le barriere mobili IBM sono composte da un pannello autoportante che può essere monoassorbente (modello IBMM) o biassorbente (modello IBMB), possono inoltre essere dotate di vetro di ispezione (modelli IBMM-V e IBMB-V).

Caratteristiche costruttive

Pannello autoportante sp. 65mm realizzato in carpenteria medio pesante e composto da:

- Lato esterno in lamiera di acciaio zincata e verniciata con funzione fonoimpedente (modello IBMM) o in lamiera forata zincata (modello IBMB)
- Strato di materiale fonoassorbente protetto da velovetro anti spolverio
- Lato interno in lamiera forata zincata
- Peso specifico: 29 kg/m² (IBMM); 36 kg/m² (IBMB)
- Peso totale: 130 kg (IBMM); 154 kg (IBMB)
- Struttura di appoggio in carpenteria verniciata dotata di ruote piroettanti
- Maniglie di presa
- Ganci rapidi
- Incombustibile classe A1
- Temperatura massima di impiego: 150°C
- Dimensioni: 1300 x 765 x H2520mm

Esecuzioni speciali

- Barriere con vetro di ispezione montato su telaio (modelli IBMM-V e IBMB-V rispettivamente per le barriere mono e biassorbenti)
- Barriere con misure a richiesta

Sound-proofing mobile barrier – IBMM/IBMB

When

The IBMM (one side sound absorbent) and IBMB (both sides sound absorbent) mobile barriers, with high sound-absorbing and sound-insulating power, are used in various industrial processes as effective acoustic confinement means if it is not possible or advantageous to construct cabins or fixed walls.

Description

The IBM model mobile barriers are equipped with wheels for easy movement and can be joined together to form linear or corner walls or to enclose working areas on three or four sides, according to requirements, using special rapid hooks.

IBM mobile barriers are composed of a self-supporting panel that can be one side sound absorbent (IBMM model) or both sides sound absorbent (IBMB model), they can also be equipped with inspection glass (IBMM-V and IBMB-V models).

Construction features

65mm self-supporting panel made of medium-heavy carpentry and composed of:

- *External side in galvanized and painted steel sheet with soundproofing function (IBMM model) or in galvanized perforated sheet (IBMB model)*
- *Layer of sound-absorbing material protected by anti-dusting glass-cloth*
- *Internal side in galvanized perforated sheet*
- *Specific weight: 29 kg/m² (IBMM); 36 kg/m² (IBMB)*
- *Total weight: 130 kg (IBMM); 154 kg (IBMB)*
- *Support structure in painted carpentry equipped with swivel wheels*
- *Grab handles*
- *Toggle clamps*
- *Incombustible class A1*
- *Maximum operating temperature: 150 ° C*
- *Dimensions: 1300 x 765 x H2520mm*

Special executions

- *Barriers with inspection glass hatch (IBMM-V and IBMB-V models)*
- *Barriers with special dimensions on request*

DATI TECNICI TECHNICAL DATA

Peso pannello <i>Panel weight</i>	130 kg
Spessore del pannello <i>Panel thickness</i>	65 mm
Resistenza al calore <i>Heat resistance</i>	Impiegabile fino a 150°C <i>Resistant to 150°C</i>
Comportamento al fuoco <i>Reaction to fire</i>	Incombustibile – Classe A1 <i>Non-combustible – A1 Class</i>
Colorazione <i>Painting</i>	RAL a scelta <i>RAL colour on demand</i>
Proprietà fonoisolanti <i>Acoustic capabilities</i>	Prestazioni effettive della singola barriera in prova <i>Sound-proofing performance of one single barrier</i>

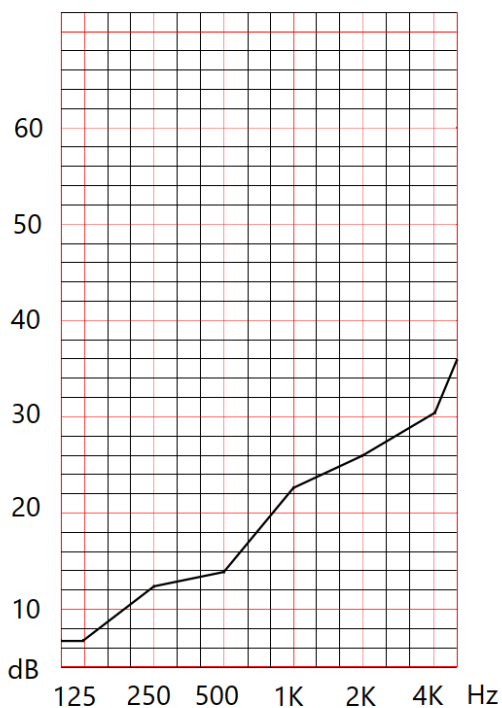

Prestazioni della barriera misurate in ambiente di lavoro.
Dimensioni della barriera: 1300xH2500mm.
Misura effettuata a 1m di distanza

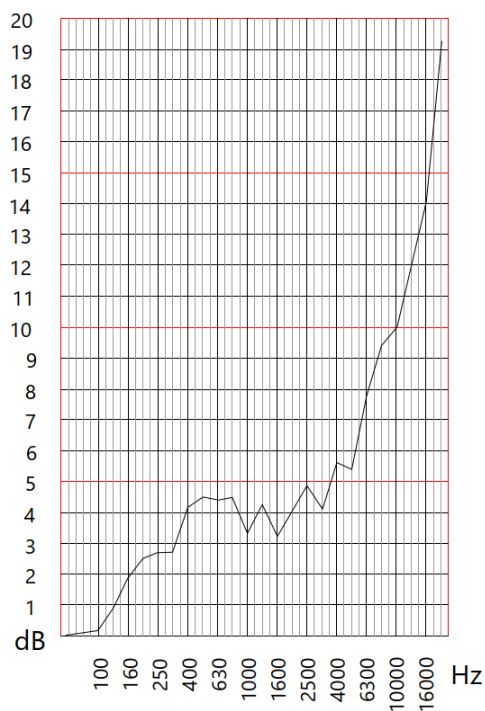

Barrier performance measured in the workplace.
Barrier dimensions: 1300xH2500mm.
Measurement performed at 1m distance



IBMM/IBMB – Elementi principali

IBMM/IBMB – Main elements

1	Lamiera zincata interna verniciata (modello IBMM e IBMM-V)/ Galvanized and painted external sheet steel (IBMM and IBMM-V model)
2	Lamiera zincata forata/Galvanized perforated steel sheet
3	Maniglie di presa/Grab handles
4	Ruote piroettanti/Swivel wheels
5	Strutture di appoggio/Support legs
6	Vetro di ispezione (modello IBMM-V e IBMB-V)/Inspection glass (IBMM-V and IBMB-V model)
7	Lamiera zincata forata esterna (modello IBMB e IBMB-V)/External perforated galvanized sheet steel (IBMB and IBMB-V model)



TABELLA DIMENSIONALE BARRIERE MOBILI IBMM/IBMB
IBMM/IBMB MOBILE BARRIERS DIMENSIONS SHEET

Modello Model	Dimensioni Dimensions [mm]	Peso Weight [kg]	Peso/Superficie Weight/Surface [kg/m ²]
IBMM	1300 x 765 x H2520	121	29
IBMM-V	1300 x 765 x H2520	128	29
IBMB	1300 x 765 x H2520	147	36
IBMB-V	1300 x 765 x H2520	154	36



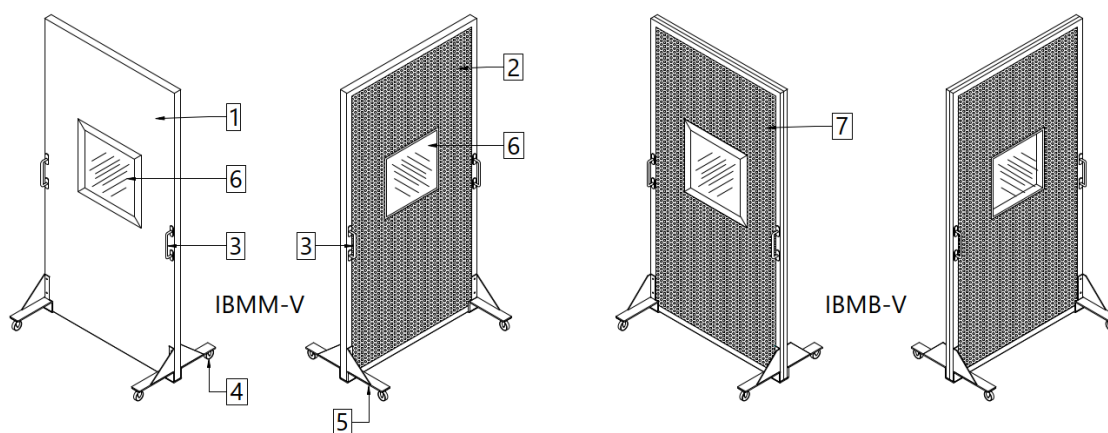

Barriera mobile insonorizzante – IBMM/IBMB

Sound-proofing mobile barrier – IBMM/IBMB

